



Installation Instructions

#51000 Hardtop & Roof Panel Storage Cart



63-67 Corvette Hardtop



68-75 Corvette Hardtop



C5 Corvette Roof Panel

Thank you for choosing this CA product. Every effort has been made to ensure the highest possible quality in regard to the appearance and functionality of this storage cart.

Tools Required: Straight blade screwdriver, ½" wrench or socket and ratchet.

A. Verify Components

Open and inspect the hardtop cart that you have received. Each cart should contain the following pieces:

- 2 – Main Frames
- 2 – Diagonal Braces

- 3 – Horizontal Braces
- 2 – 5/16" X 1 1/4" Bolts
- 4 – Casters
- 8 – 5/16" Hex Nuts
- 8 – 5/16" Lock Washers
- 8 – 5/16" Flat Washers
- 2 – 5/16" X 1" Bolts

B. Assembly Instructions

The two horizontal braces on the bottom of the cart must go under the main frame, between the casters & the main frames. Insert the threaded stem of the casters through the holes in the ends of the horizontal braces & then through the holes in the bottom of the

100 Classic Car Drive, Reedsville, PA 17084
(877) 4AAAdirect or (877) 422-2347 • Fax: 717-667-3174
Email: customerservice@AAAdirect.com • www.AAAdirect.com



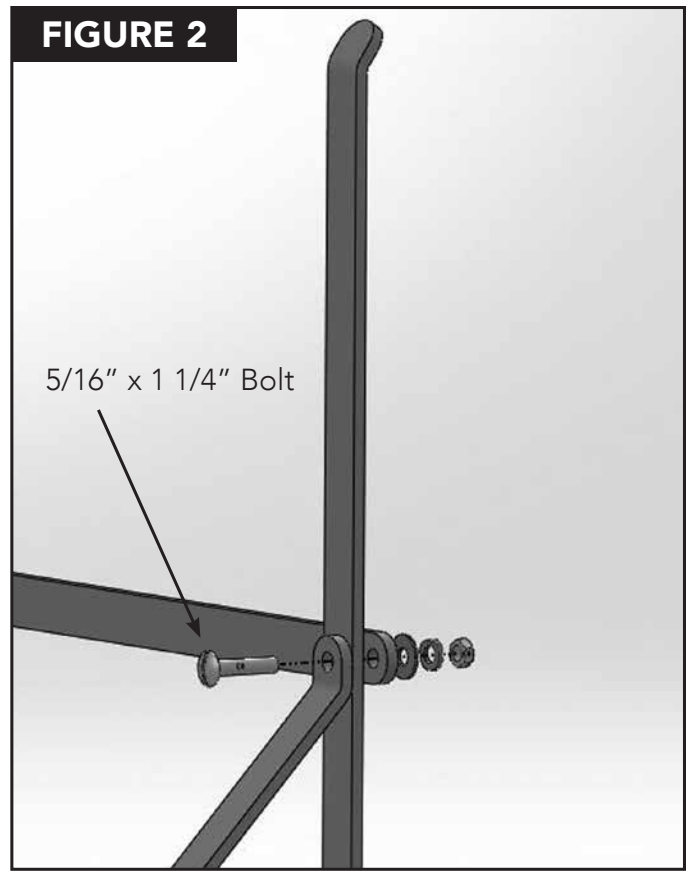
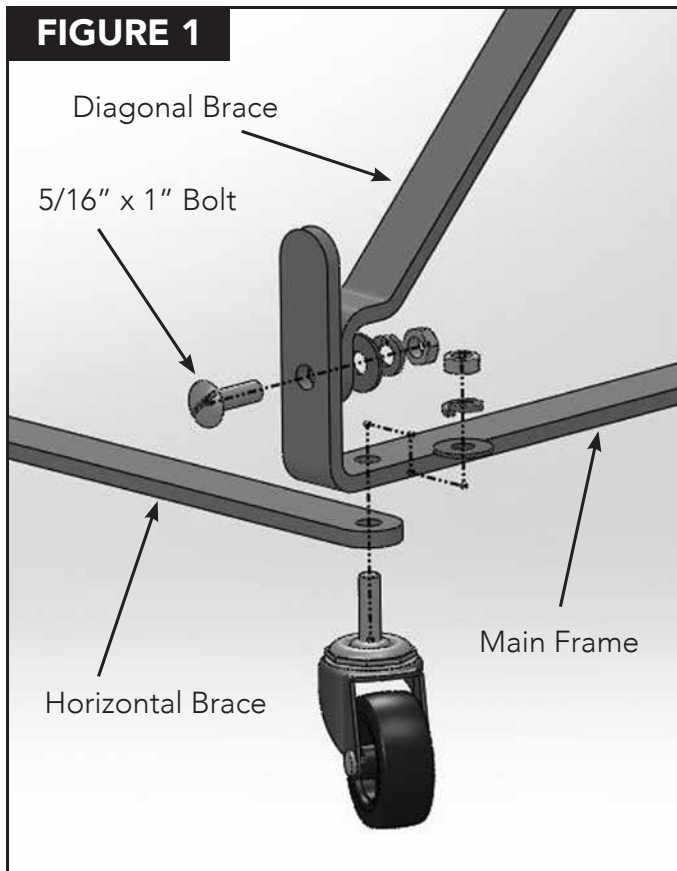

main frames. Place a flat washer & a lock washer on each caster stem & install a hex nut to secure. Hand tighten for now. Repeat for all four casters. **Figure 1.**

Place the diagonal braces in position on the main frames. The padded side faces up and the end with the double bend attaches to the short leg of the main frame.

Insert a 5/16" X 1" bolt through the hole in the short leg of the main frame and then through the hole in the diagonal brace. Install a flat washer, lock washer and hex nut and hand tighten. Repeat for the other diagonal brace. **Figure 1.**

Insert a 5/16" x 1 1/4" bolt through the hole in the upper end of the diagonal brace and through the hole

in the long leg of the main frame. Place the remaining horizontal brace in position by placing the hole in the end of the brace over the bolt.

Secure with a flat washer, lock washer and hex nut. Hand tighten. Repeat for the other end.

Figure 2. Ensure the cart is square & that the horizontal braces are at right angles to the main frames. Adjust if necessary. Tighten all the nuts securely using a half inch wrench or socket and ratchet.

C. Hardtop / Roof Panel Storage

This cart is designed so that the hardtop is placed on the cart with the rear window of the top down and the exterior top of the hardtop / roof panel resting against the long, padded, upright legs of the main frames.

100 Classic Car Drive, Reedsville, PA 17084

(877) 4AAAdirect or (877) 422-2347 • Fax: 717-667-3174

Email: customerservice@AAAdirect.com • www.AAAdirect.com



This provides the lowest center of gravity and the most stability when the top is on the cart.

Be especially careful when using the cart for 1968-75 Corvette hardtops as the rear corners of that model year top are pointed and extend past the edge of the top. They can be easily damaged if the top is dropped or not centered on the cart.

Precautions

1. Always use at least two people to lift & move your hardtop or roof panel.
2. Be very careful when placing your top on the cart or removing it from the cart.
3. Even though all contact points on the cart are padded, it is recommended that a protective cover be placed on your top before storing it on the cart.
4. Store your top & cart on a hard, flat, level surface.

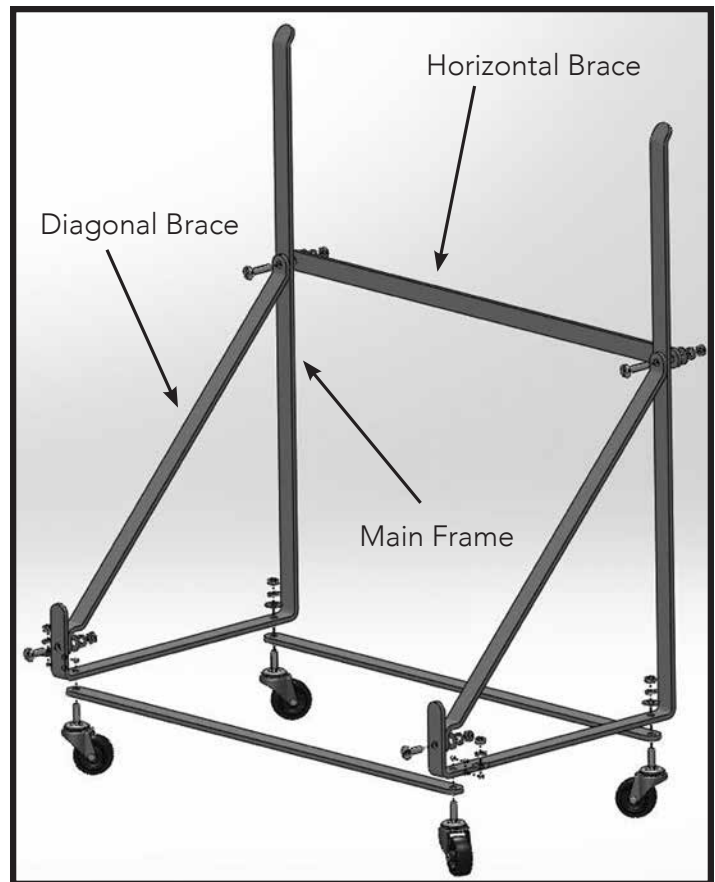

100 Classic Car Drive, Reedsville, PA 17084

(877) 4AAAdirect or (877) 422-2347 • Fax: 717-667-3174

Email: customerservice@AAAdirect.com • www.AAAdirect.com

